

# CATALOGO DE PERFILES SISTEMA NIZA



4 .....	Indice de Perfiles
8 .....	Tabla de Tipologías
	Detalle de Perfiles en Escala 1:1
9 .....	Ventana y Puerta Corrediza N-Uno Hoja a 45°
11 .....	Marco N-Tres / N-Cinco
12 .....	Hoja de Rebatir N-Tres / N-Cinco
13 .....	Ventana de Rebatir / Desplazable N-Tres / N-Cinco
14 .....	Marco y Jamba Corrediza N-Tres / N-Cinco
15 .....	Adicionales Marco Corrediza N-Tres / N-Cinco
16 .....	Hoja Corrediza VS N-Tres Corte 90°
17 .....	Hoja Corrediza DVH N-Tres Corte 90°
18 .....	Hoja Corrediza VS - DVH / N-Cinco Corte 45°
19 .....	Complemento Fijo Móvil N-Tres / N-Cinco
20 .....	Contramarcos
21 .....	Premarcos/ Guías Cortina
22 .....	Acoples y Refuerzos
23 .....	Tubos

La Línea Niza ofrece tres niveles de prestación:

N-Uno: Media prestación para dimensiones convencionales





















N-Tres: Alta prestación para dimensiones convencionales



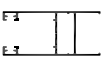

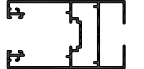

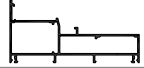
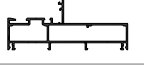









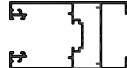





N-Cinco: Alta prestación para grandes dimensiones



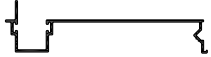







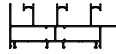



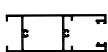

**Peso de las Barras de Perfiles:** El peso por metro de los perfiles es estimado, con una tolerancia de + / - 10%.



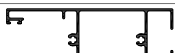



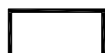
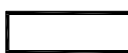
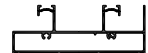
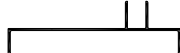

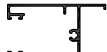

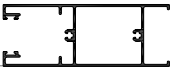



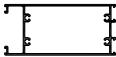

**Largo de las Barras de Perfiles:** La medida Standard de las Barras de Perfiles es de 6.030 milímetros, salvo aclaración en contrario.

**Alsafex S.A.** se reserva el derecho de realizar cambios y/o modificaciones sin previo aviso de los contenidos y artículos indicados en el presente catálogo.

CODIGO	PESO (Kg/m.)	LARGO (mm.)	DESCRIPCION	FORMA	PAG.
1110051	0,27	6.030	Contravidrio recto 37 mm para clip		21
1110052	0,21	6.030	Contravidrio recto 19 mm para clip		21
1110053	0,19	6.030	Contravidrio recto 11 mm para clip		21
1110065	1,30	6.030	Parante Fijo Móvil 40 mm		20
1110067	0,55	6.030	Cierre marco Fija Móvil N-tres / N-Cinco		20
1110068	0,71	6.030	Cierre parante Fija Móvil N-Cinco		20
1110069	0,42	6.150	Guía Fija Móvil N-tres / N-Cinco		20
1110189	1.09	6.030	Encuentro central ventana de abrir		13
1060200	0,15	6.030	Bota-Agua Puerta de Rebatir N-Tres y N-Cinco		12
1110204	0,31	6.150	Perfil de acople		23
1110208	1,06	6.150	Hoja recta de abrir		13
1110299	1,67	6.150	Perfil de acople reforzado N-Tres		23
1110353	1,05	6.030	Travesaño Paño fijo N-Tres / N-Cinco		11
1110404	1,16	6.150	Marco Corrediza de dos guías N-Uno		9
1060405	0,72	6.030	Hoja Corrediza VS N-Uno		9
1060406	0,68	6.030	Hoja Corrediza DVH N-Uno		9
1110408	0,46	6.150	Solapa de Cruce de Hojas Corredizas 45° N-Cinco.		19
1110409	1,34	6.150	Hoja Corrediza 45° VS N-Cinco		19
1110410	1,26	6.150	Hoja Corrediza 45° DVH N-Cinco		19
1110414	1,49	6.150	Marco Ventana Desplazable N-Cinco		13
1110424	1,49	6.150	Marco PF / Puerta y Ventana de Abrir N-Cinco / Fijo-Móvil N-Tres.		11
1110441	1,02	6.150	Hoja Mosquitero N-Tres/ N-Cinco		15
1110442	0,51	6.150	Guía Mosquitero Corrediza N-Tres / N-Cinco		15

CODIGO	PESO (Kg/m.)	LARGO (mm.)	DESCRIPCION	FORMA	PAG.
1110443	0,92	6.150	Umbral y Dintel de Marco Adicional N-Tres / N-Cinco		15
1110444	0,69	6.150	Jamba Corrediza Adicional Lisa N-Tres / N-Cinco		15
1110445	0,82	6.150	Jamba Corrediza Adicional Con U N-Tres N-Cinco		15
1110446	0,49	6.150	Encuentro Central Corrediza de 4 Hojas N-Tres N-Cinco		15
1110447	0,70	6.150	Perfil de Acople 180° Perfiles Base 114mm		23
1090459	1,01	6.030	Tubo de 60 x 60mm		24
1110467	1,29	6.150	Hoja Corrediza 45° DVH 28mm N-Cinco		18
1110469	0,18	6.030	U Postiza Jamba N-Tres / N- Cinco		15
1060543	0,13	6.030	Guía Inferior Marco Corrediza Radio 3mm		14
1060561	0,09	6.030	Guía Inferior Ventana y Puerta Corrediza		14
1060590	0,20	6.030	Encuentro Central para 4 Hojas		10
1020638	0,73	6.030	Travesaño Hoja Corrediza VS N-Uno		10
1020641	0,33	6.150	Contramarco Curvo de 42mm		21
1060647	0,46	6.150	Premarco de 48 mm.		22
1020649	0,19	6.150	Contramarco Recto.		21
1020657	0,19	6.150	Contramarco de 28mm		21
1020681	0,70	6.030	Travesaño Hoja Corrediza DVH N-Uno		10
1020684	0,89	6.150	Guía Cortina Regulable		22
1020685	0,38	6.030	Hoja Mosquitero N-Uno		10
1090700	2,68	6.150	Tubo 115 x 115mm		23
1110701	1,16	6.150	Perfil de Acople 180° 3 Guías Perfiles base 170mm		23
1110716	1,04	6.150	Parante Lateral Hoja Corte 90° DVH N-Tres		17
1110717	1,16	6.150	Parante Central Hoja Corte 90° DVH N-Tres		17

CODIGO	PESO (Kg/m.)	LARGO (mm.)	DESCRIPCION	FORMA	PAG.
1020718	0,33	6.150	Premarco 36mm		22
1020721	1,68	6.150	Marco 3 Guías N-Uno		21
1020722	0,49	6.150	Guía Cortina Común		22
1110724	0,91	6.030	Zócalo y Cabezal Hoja Corte 90° DVH N-Tres		17
1060725	0,26	6.030	Tope Inferior Umbral Puerta de Rebatir N-Tres y N-Cinco		12
1110728	1,49	6.030	Zócalo Alto Hoja Corte 90° VH N-Tres.		17
1110734	0,79	6.150	Marco Ventana Desplazable N-Tres		13
1110735	1,25	6.150	Hoja Recta Ventana Desplazable N-Tres / N-Cinco		13
1110740	1,10	6.150	Parante Lateral Hoja Corte 90° VS N-Tres		16
1060743	0,29	6.030	Encuentro de Hoja Ventana y Puerta Corrediza N-Uno		10
1110744	1,21	6.150	Parante Central Hoja Corte 90° VS N-Tres		16
1110745	0,98	6.030	Zócalo y Cabezal Hoja Corte 90° VS N-Tres		16
1110748	1,54	6.030	Zócalo Alto corte 90° VS N-Tres		16
1070772	0,44	6.030	Umbral Transitable para Puerta de Rebatir N-Tres / N-Cinco		12
1110793	2,54	6.150	Umbral / Dintel Marco Corrediza 3 Guías N-Tres / N-Cinco		14
1110794	2,20	6.150	Jamba Marco Corrediza 3 Guías N-Tres / N-Cinco		14
1090809	0,55	6.030	Tubo Rectangular 50x25mm		24
1090812	0,64	6.030	Tubo Rectangular 60x20mm		24
1110864	1,79	6.150	Umbral / Dintel Marco Corrediza 2 Guías N-Tres / N-Cinco		14
1110865	1,29	6.150	Jamba Marco Corrediza 2 Guías N-Tres / N-Cinco.		14
1110866	1,02	6.150	Parante Hoja Lateral Corte 90° DVH N-Tres		18
1110867	1,13	6.150	Parante Central Hoja Corte 90° DVH N-Tres		18
1110868	0,89	6.030	Zócalo y Cabezal Hoja Corte 90° DVH N-Tres		18

CODIGO	PESO (Kg/m.)	LARGO (mm.)	DESCRIPCION	FORMA	PAG.
1110869	1,47	6.030	Zócalo Alto Hoja Corte 90° DVH N-Tres.		18
1060875	0,88	6.150	Premarco de 95 mm.		21
1110998	1,08	6.150	Refuerzo Inercial 61mm		23
1110999	1,45	6.150	Refuerzo inercial 100mm		12
3083	0,35	6.200	Contramarco p/ Atornillar		12
4040	1,18	6.200	Marco Puerta de Rebatir Coplanar		23
4041	1,39	6.200	Hoja Puerta de Rebatir		22
4042	1,40	6.200	Travesaño Puerta de Rebatir		11
4043	2,32	6.200	Zócalo Puerta de Rebatir		12
4044	1,04	6.200	Encuentro Central Puerta de Rebatir		12
4045	0,35	6.200	Contravidrios Recto p/DVH. Paño Fijo		21
4046	0,27	6.200	Contravidrios Recto Paño Fijo		21
4047	0,25	6.200	Contravidrios Curvo Paño Fijo		21
4048	0,20	6.200	Contravidrios Curvo p/DVH. Paño Fijo		21
4049	0,23	6.200	Contravidrios Recto Exterior Puerta de Rebatir		21
4050	0,19	6.200	Contravidrios Curvo Exterior Puerta de Rebatir		21
4059	1,00	6.200	Marco Paño Fijo Recto / Puerta de Rebatir no Coplanar		11

Niza N-Uno		
	Marco	Hoja
Ventana y Puerta Corrediza - Hoja a 45°	1110404 / 1110721	1110405 / 1110406

Niza N-Tres		
	Marco	Hojas
Paño Fijo	4059	
Ventana de Rebatir / Banderola/ OB	4059	1110208
Ventana desplazable	1110734	1110735
Puerta de Rebatir Coplanar	4040	4041
Puerta de Rebatir No Coplanar	4059	4041
Ventana y Puerta Corrediza	1110864 / 1110865 1110793 / 1110794	VS 1110740 / 1110744 DVH 1110866 / 1110867
Fijo Móvil	1110424	VS 1110740 / 1110744 DVH 1110866 / 1110867

Niza N-Cinco		
	Marco	Hojas
Paño Fijo	1110424	
Ventana de Rebatir / Banderola/ OB	1110424	1110208
Ventana desplazable	1110414	1110735
Puerta de Rebatir	1110424	4041
Ventana y Puerta Corrediza	1110864 1110865/ 1110793 1110794	VS 1110409 DVH 1110467 / 1110410
Fijo Móvil	1110424	VS 1110409DVH 1110467 1110410



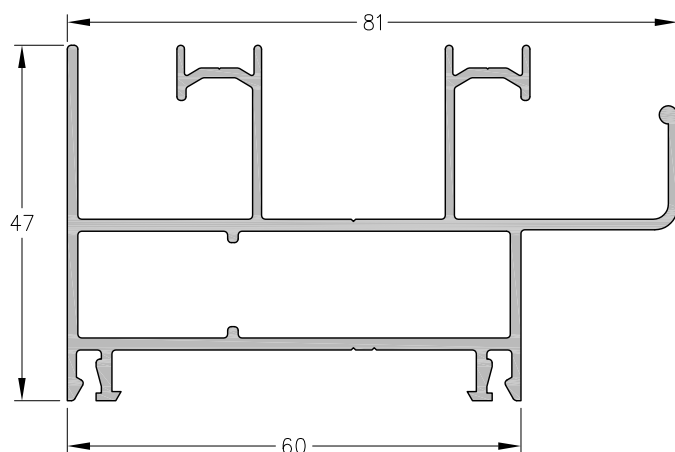

**1110404 - Marco corrediza dos guías**  
Peso: 1,16 Kg/m  
Largo Std.: 6150 mm

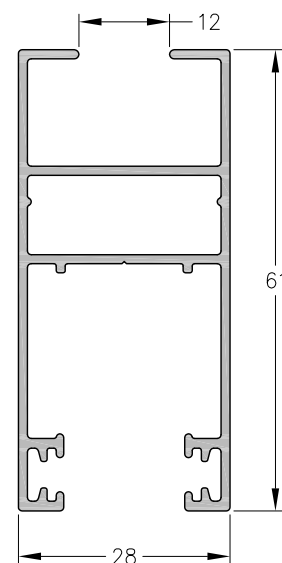

**1060405 - Hoja corrediza VS**  
Peso: 0,72 Kg/m  
Largo Std.: 6030 mm

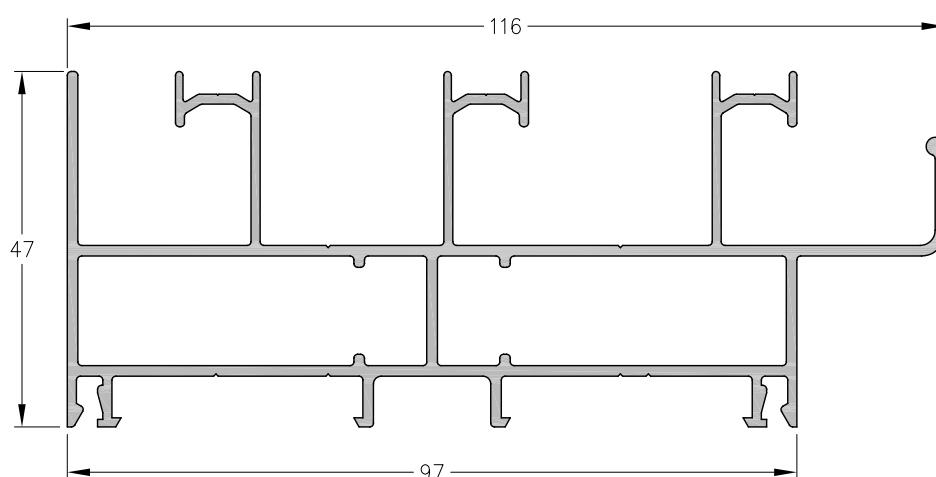

**1110721 - Marco tres guías N-UNO**  
Largo Std.: 6150 mm  
peso: 1,68 Kg/m

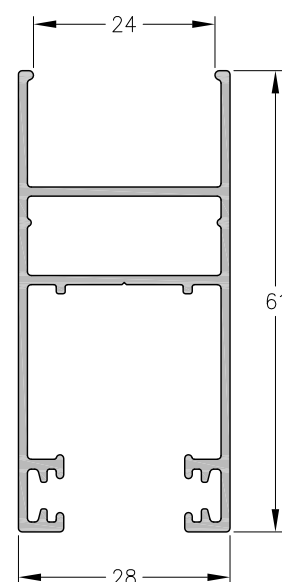

**1060406 - Hoja corrediza DVH**  
Peso: 0,68 Kg/m  
Largo Std.: 6030 mm

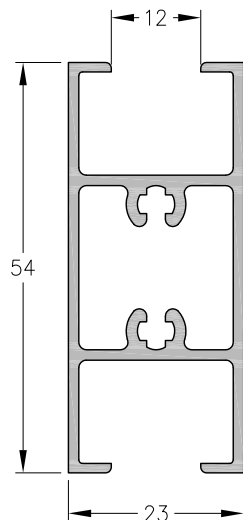

1020638 - Travesaño para  
hoja N-Uno  
Peso: 0,73Kg/m  
Largo Std.: 6030 mm

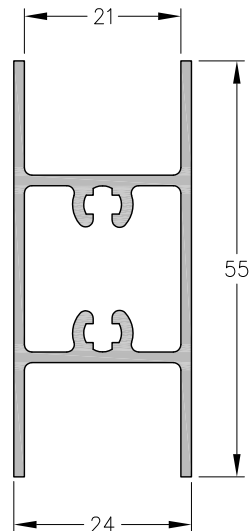

1020681 - Travesaño para  
Hoja N-Uno  
Peso: 0,70 Kg/m  
Largo Std.: 6030 mm

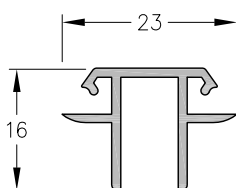

1060590 - Encuentro 4 Hojas  
para Corrediza N-Uno  
Peso: 0,20 Kg/m  
Largo Std.: 6030 mm

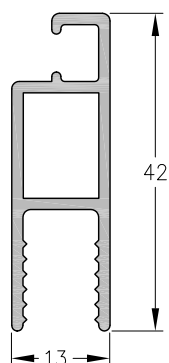

1020685 - Mosquitero  
Peso: 0,38 Kg/m  
Largo Std.: 6030 mm



1060743 - Encuentro  
Central de Hoja  
Peso: 0,29 Kg/m  
Largo Std.: 6030 mm

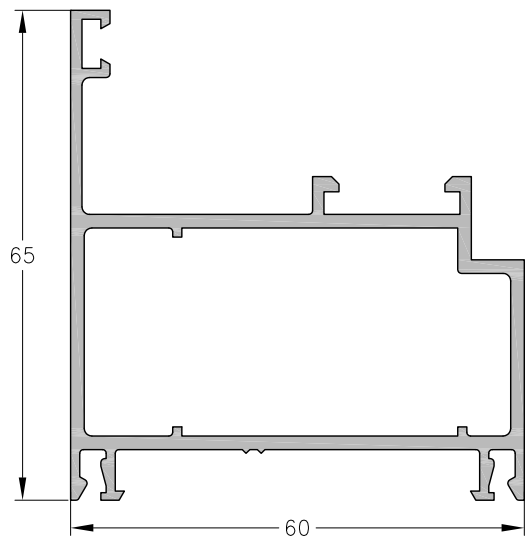

**4040 - Marco Puerta coplanar**  
Peso: 1,18 Kg/m.  
Largo Std.: 6.200 mm.

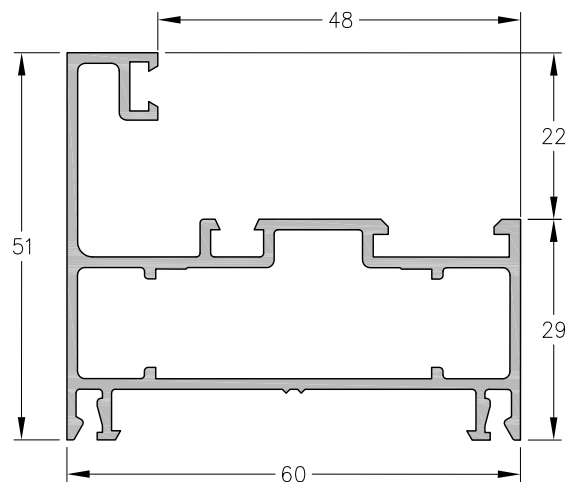

**4059 - Marco Paño Fijo Recto,**  
Ventana de Rebatir N3.  
Peso: 1.00 Kg/m.  
Largo Std.: 6.200 mm.

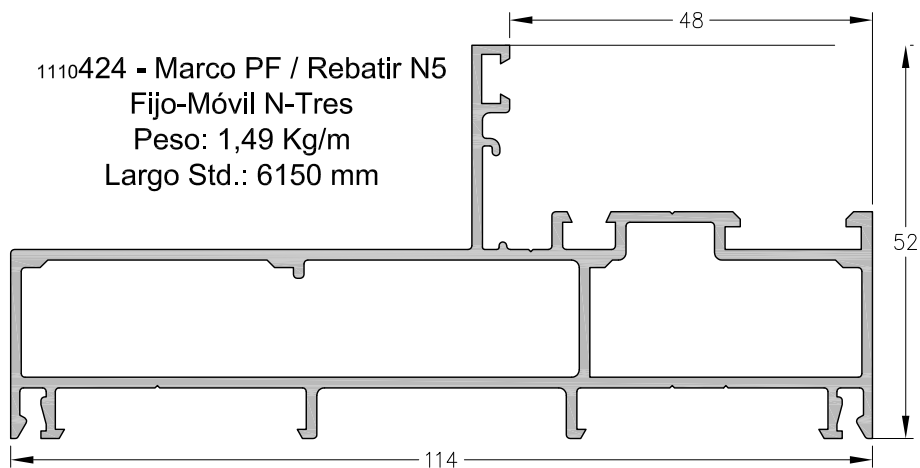

**1110424 - Marco PF / Rebatir N5**  
Fijo-Móvil N-Tres  
Peso: 1,49 Kg/m  
Largo Std.: 6150 mm

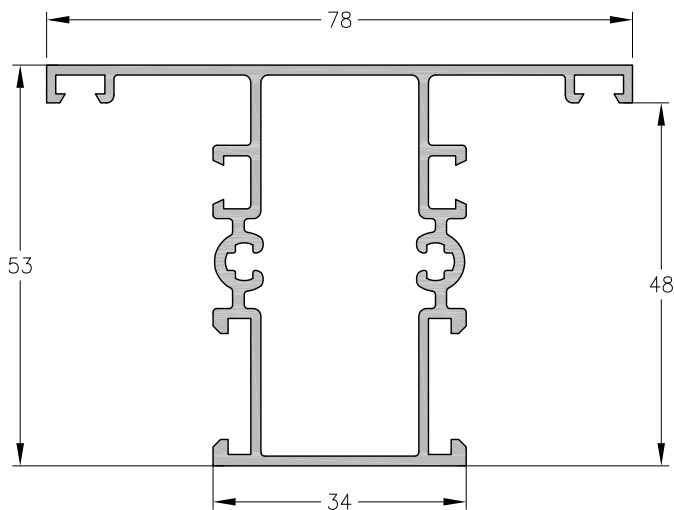

**1110353 - Travesaño paño fijo**  
Peso: 1,05 Kg/m  
Largo Std.: 6030 mm

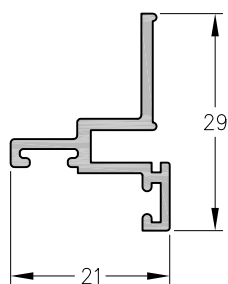
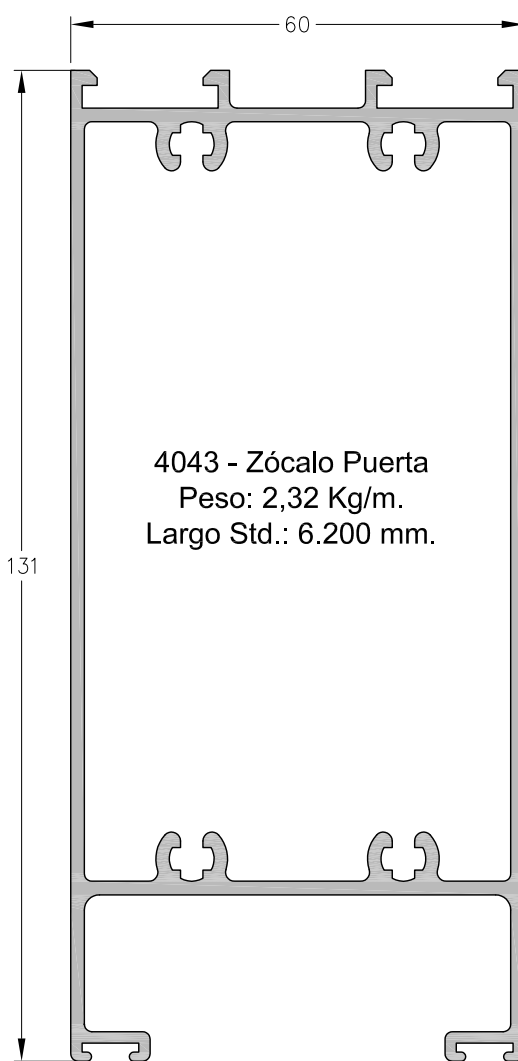
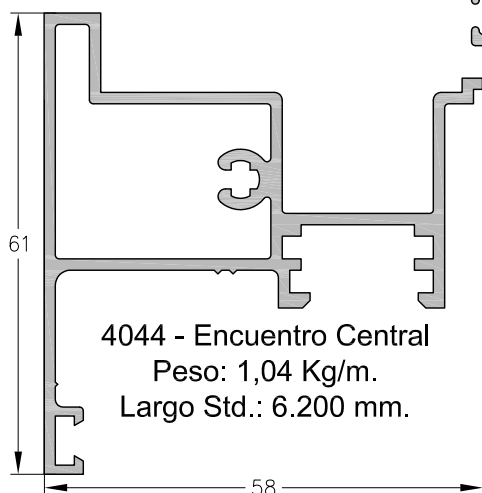
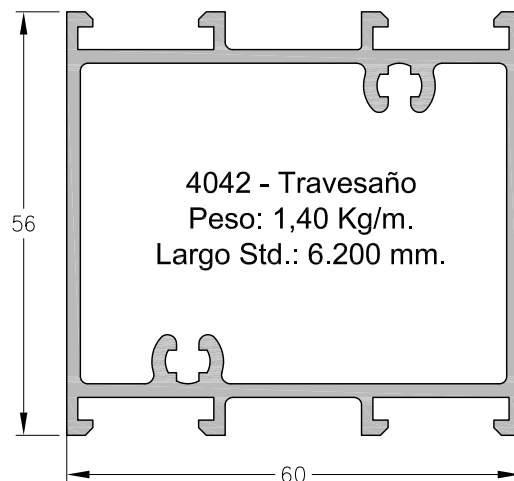
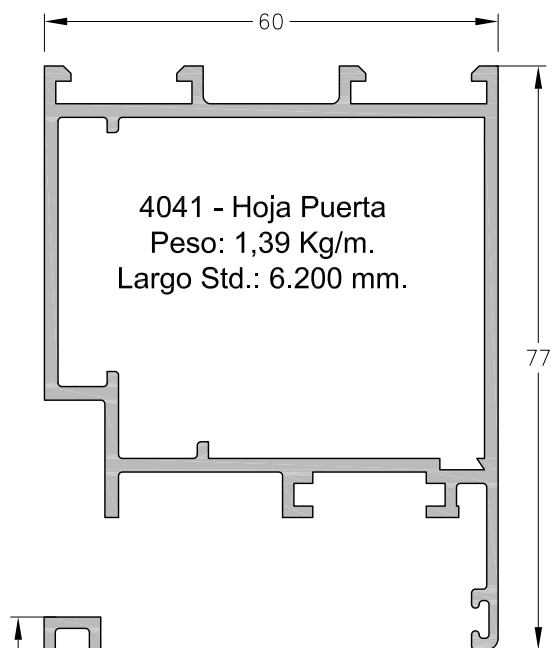

1060725 - Tope Inferior Umbral  
Peso: 0,26 Kg/m  
Largo Std.: 6030 mm

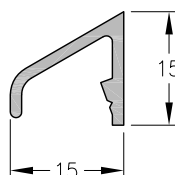

1060200 - Bota-Agua  
peso: 0,15 Kg/m

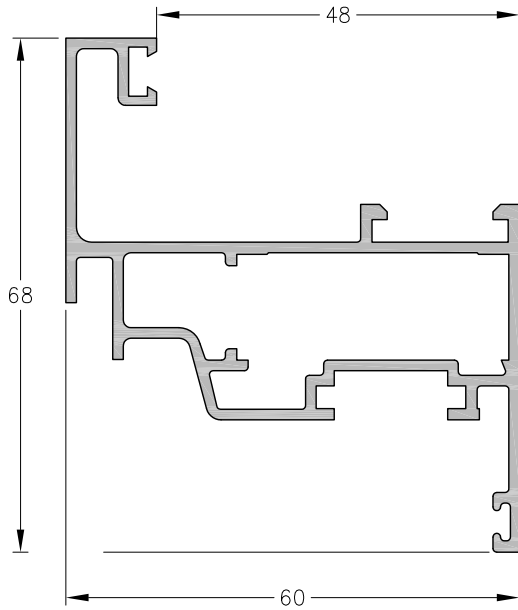

**1110208 - Hoja recta ventana de abrir**  
Peso: 1,06 Kg/m  
Largo Std.: 6150 mm

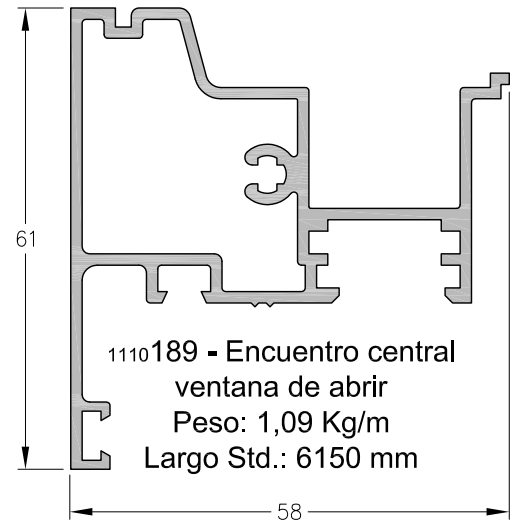

**1110189 - Encuentro central  
ventana de abrir**  
Peso: 1,09 Kg/m  
Largo Std.: 6150 mm

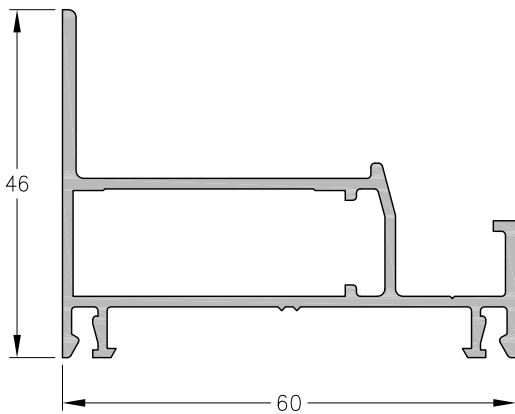

**1110734 - Marco ventana desplazable N3**  
Peso: 0,79 Kg/m  
Largo Std.: 6150 mm

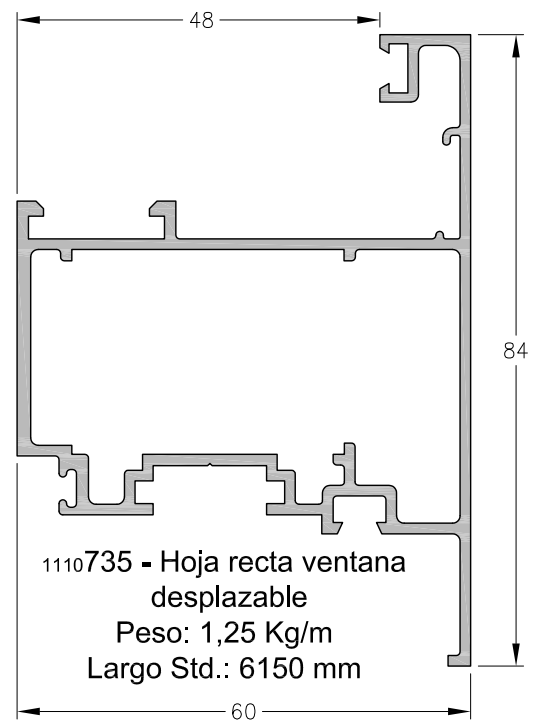

**1110735 - Hoja recta ventana  
desplazable**  
Peso: 1,25 Kg/m  
Largo Std.: 6150 mm

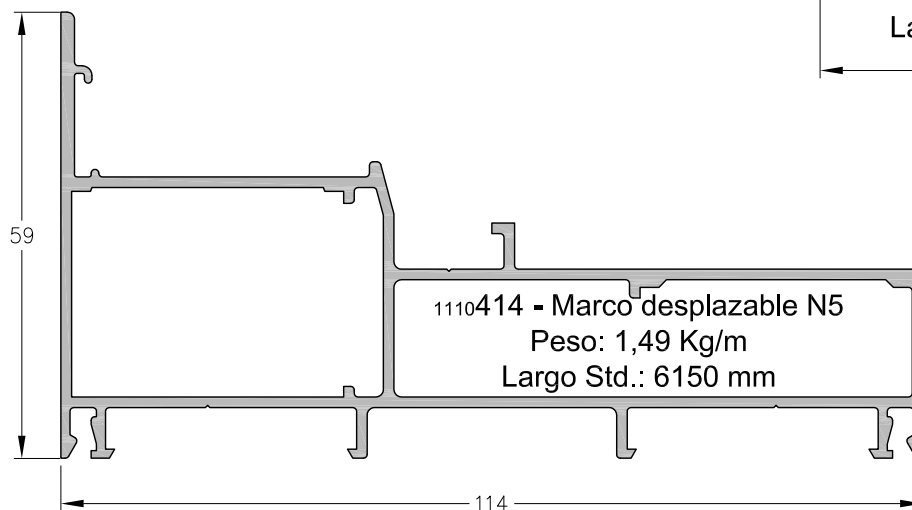

**1110414 - Marco desplazable N5**  
Peso: 1,49 Kg/m  
Largo Std.: 6150 mm

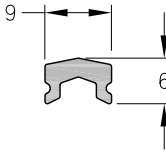

**1060561 - Guía Inferior Corrediza**  
Peso: 0,09 Kg/m  
Largo Std.: 6030 mm

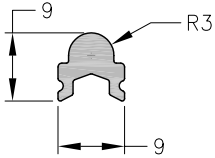

**1060543 - Guía Inferior corrediza radio 3 mm**  
Peso: 0,13 Kg/m  
Largo Std.: 6030 mm

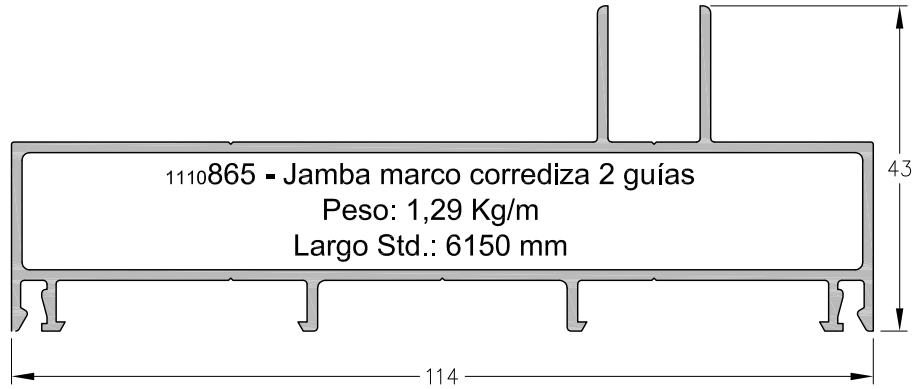

**1110865 - Jamba marco corrediza 2 guías**  
Peso: 1,29 Kg/m  
Largo Std.: 6150 mm

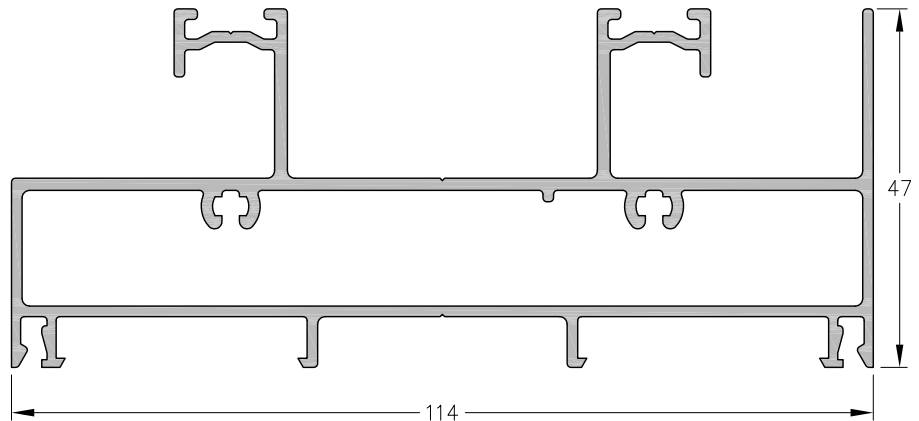

**1110864 - Umbral / dintel marco corrediza 2 guías**  
Peso: 1,79 Kg/m  
Largo Std.: 6150 mm

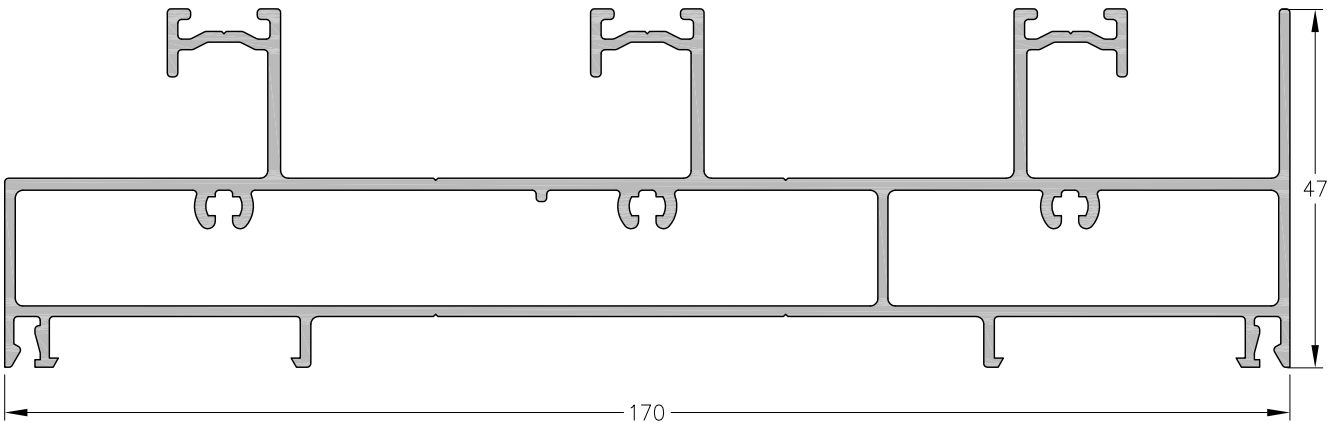

**1110793 - Umbral Dintel 3 guías**  
Peso: 2,54 Kg/m  
Largo Std.: 6150 mm

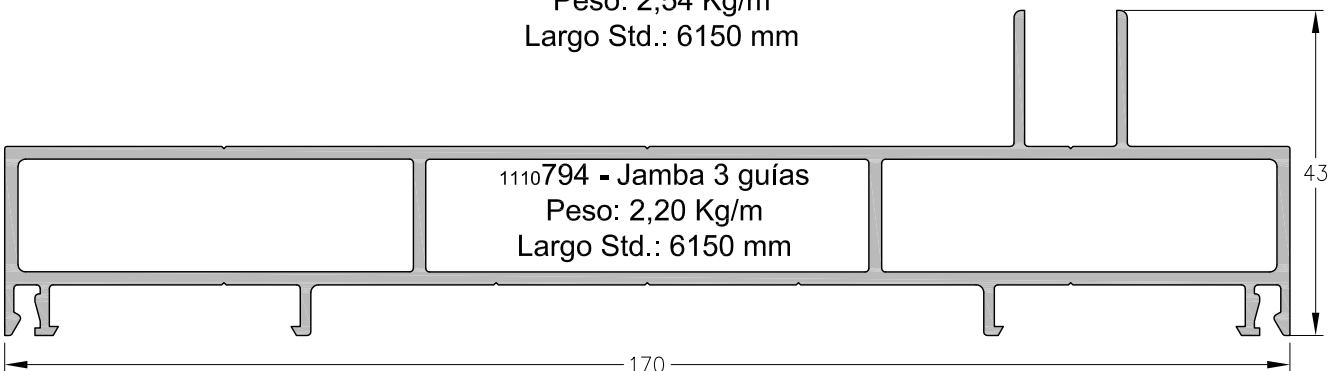

**1110794 - Jamba 3 guías**  
Peso: 2,20 Kg/m  
Largo Std.: 6150 mm

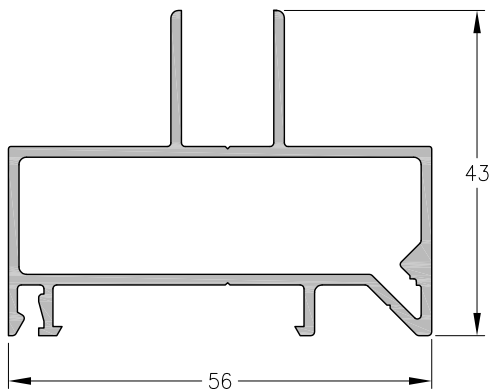

1110445 - Jamba adicional con U  
Peso: 0,82 Kg/m  
Largo Std.: 6150 mm

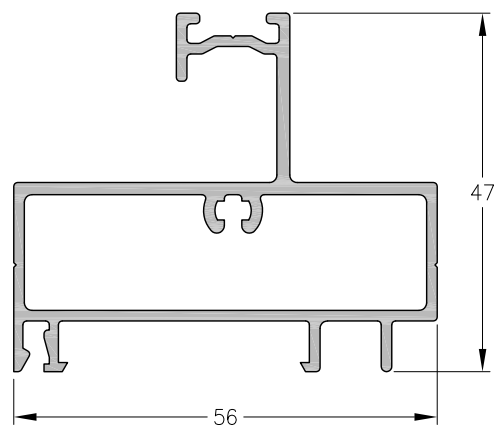

1110443 - Umbral / dintel adicional  
Peso: 0,92 Kg/m  
Largo Std.: 6150 mm

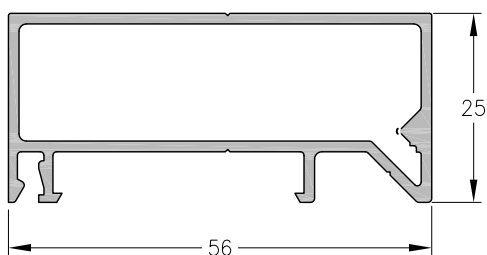

1110444 - Jamba adicional lisa  
Peso: 0,69 Kg/m  
Largo Std.: 6150 mm

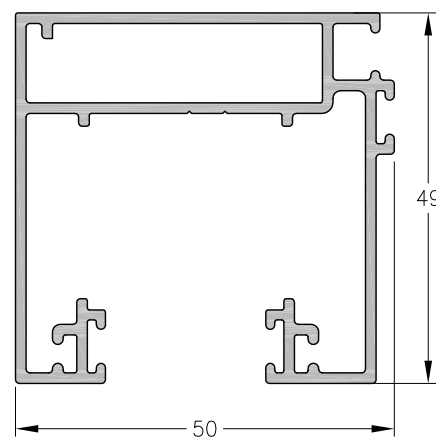

1110441 - Mosquitero corredizo  
Peso: 1,02 Kg/m  
Largo Std.: 6150 mm

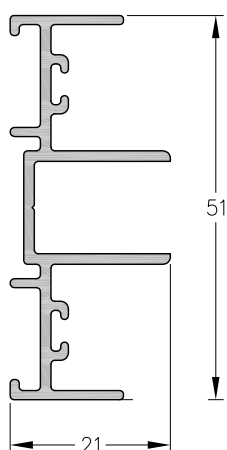

1110446 - Encuentro central  
cuatro hojas  
Peso: 0,49 Kg/m  
Largo Std.: 6150 mm

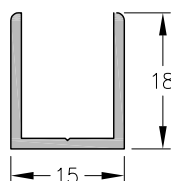

1110469 - U postiza Jamba  
Peso: 0,18 Kg/m  
Largo Std.: 6030 mm

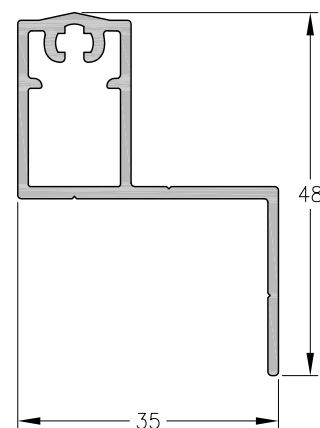

1110442 - Guía mosquitero  
Peso: 0,51 Kg/m  
Largo Std.: 6150 mm

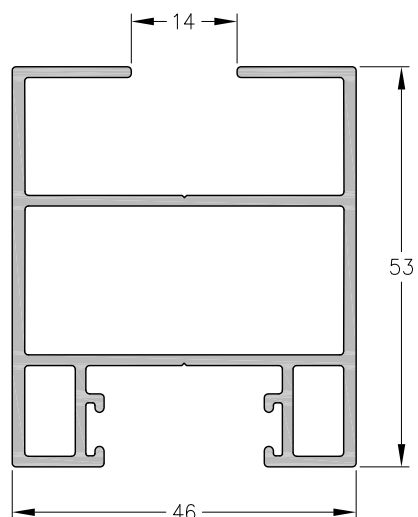

1110740 - Parante lateral hoja corte 90° VS  
 Peso: 1,10 Kg/m  
 Largo Std.: 6150 mm

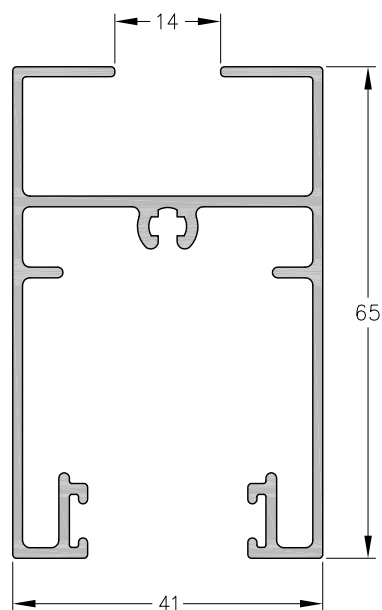

1110745 - Zócalo y cabezal hoja corte 90° VS  
 Peso: 0,98 Kg/m  
 Largo Std.: 6030 mm

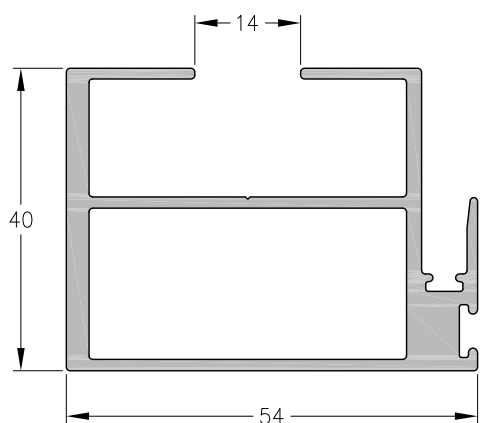

1110744 - Parante central hoja corte 90° VS  
 Peso: 1,21 Kg/m  
 Largo Std.: 6150 mm

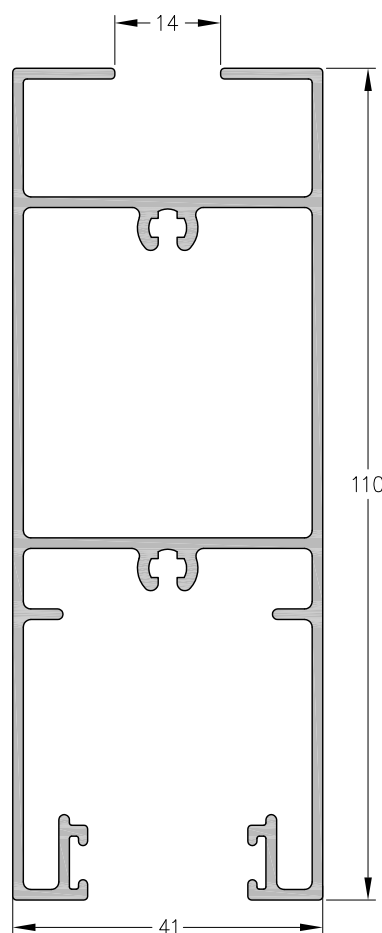

1110748 - Zócalo alto hoja corte 90° VS  
 Peso: 1,54 Kg/m  
 Largo Std.: 6030 mm



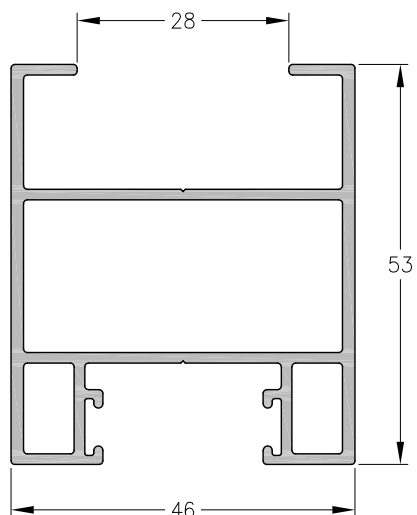

1110716 - Parante lat hoja 90° DVH 28 mm  
Largo Std.: 6150 mm  
peso: 1,04 Kg/m

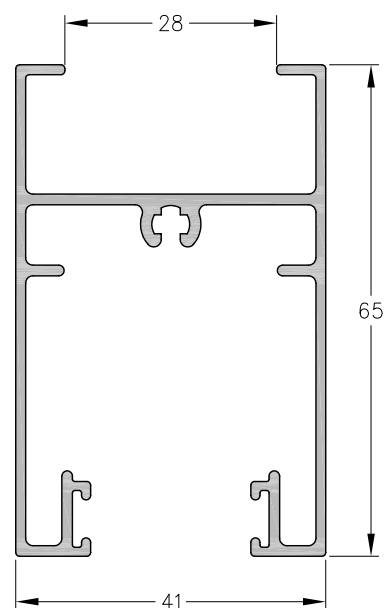

1110724 - Zócalo /cabezal hoja 90° DVH 28 mm  
Largo Std.: 6030 mm  
peso: 0,91 Kg/m

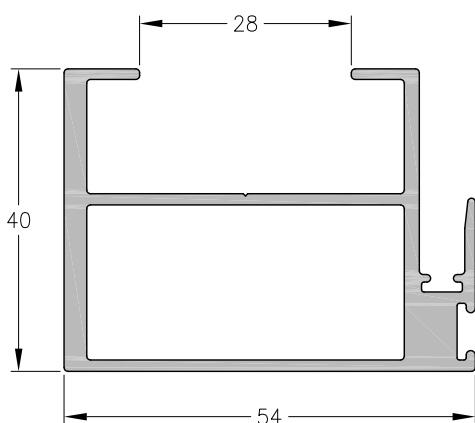

1110717 - Parante cent hoja 90° DVH 28 mm  
Largo Std.: 6150 mm  
peso: 1,16 Kg/m

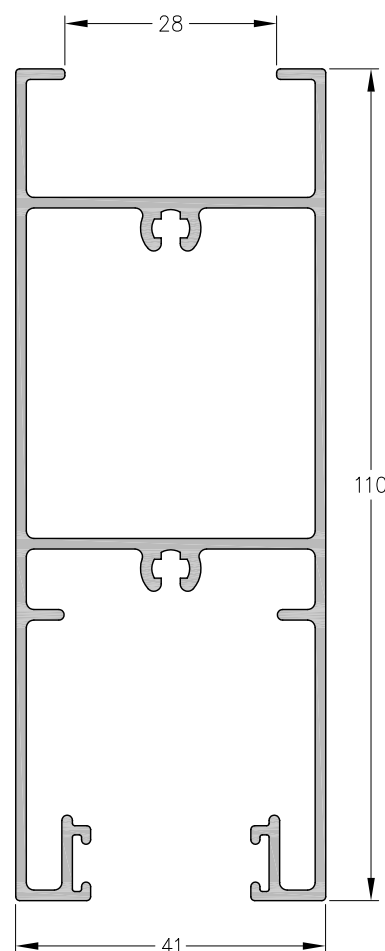

1110728 - Zócalo alto hoja 90° DVH 28 mm  
Largo Std.: 6030 mm  
peso: 1,49 Kg/m

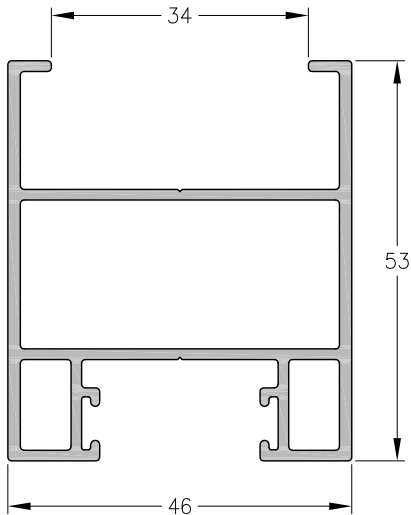

**1110866 - Parante lateral hoja corte 90° DVH**  
Peso: 1,02 Kg/m  
Largo Std.: 6150 mm

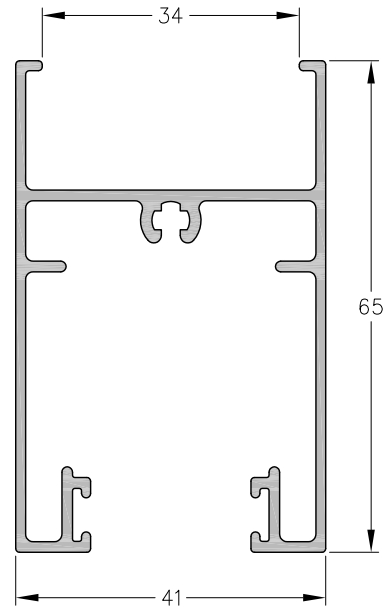

**1110868 - Zócalo y cabezal hoja corte 90° DVH**  
Peso: 0,89 Kg/m  
Largo Std.: 6030 mm

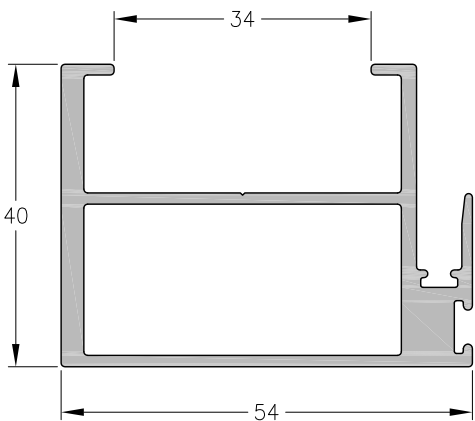

**1110867 - Parante central hoja corte 90° DVH**  
Peso: 1,13 Kg/m  
Largo Std.: 6150 mm

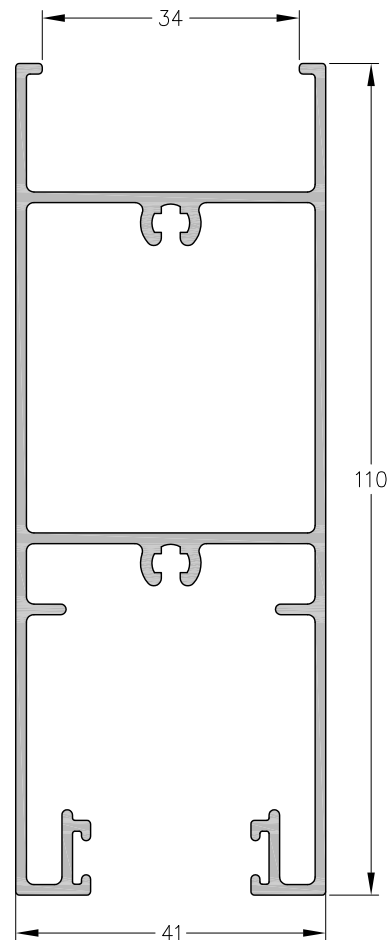

**1110869 - Zócalo alto hoja corte 90° DVH**  
Peso: 1,47 Kg/m  
Largo Std.: 6030 mm

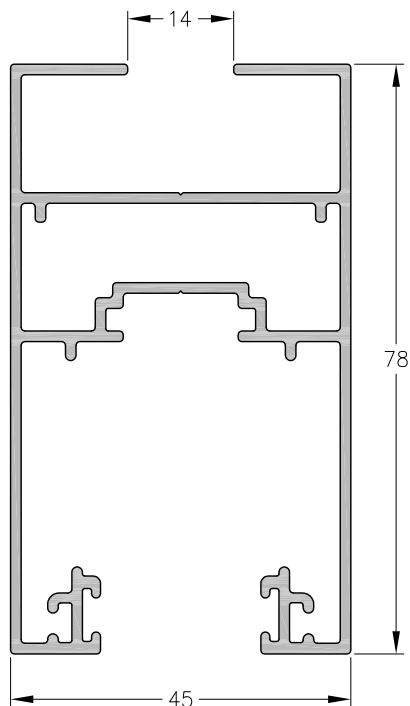

1110409 - Hoja Corrediza 45° VS  
Peso: 1,34 Kg/m  
Largo Std.: 6150 mm

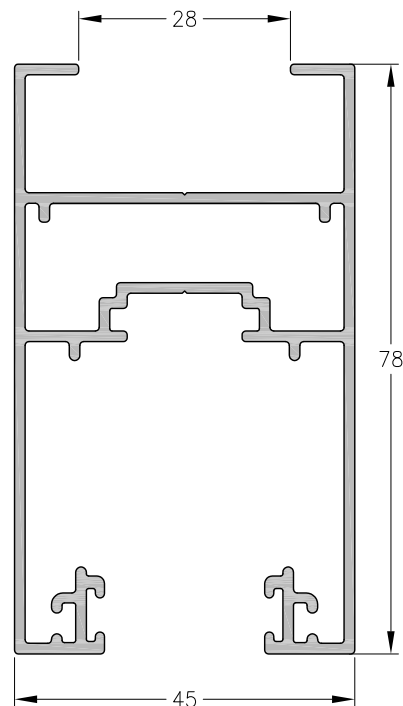

1110467 - Hoja Corrediza 45°  
DVH 28 mm  
Peso: 1,29 Kg/m  
Largo Std.: 6150 mm

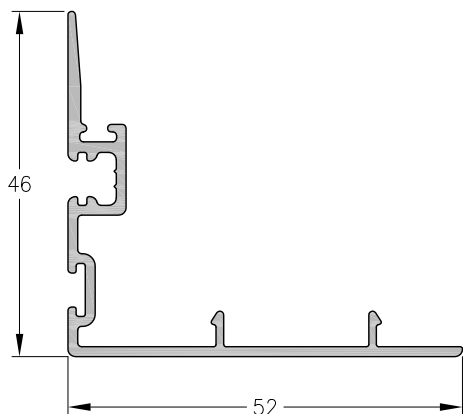

1110408 - Solapa de cruce de hojas corredizas  
Peso: 0,46 Kg/m  
Largo Std.: 6150 mm

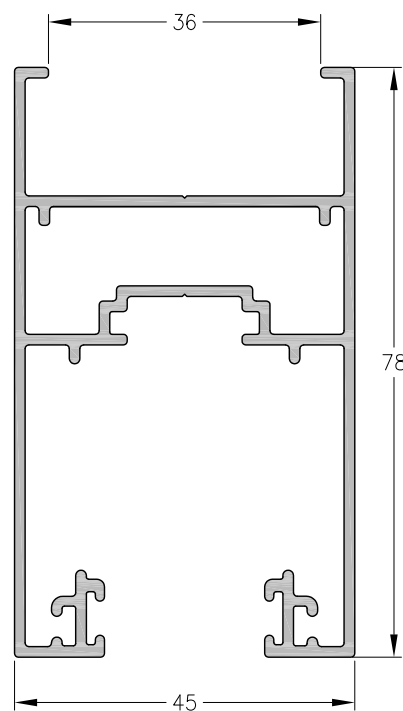

1110410 - Hoja Corrediza 45° DVH  
Peso: 1,26 Kg/m  
Largo Std.: 6150 mm

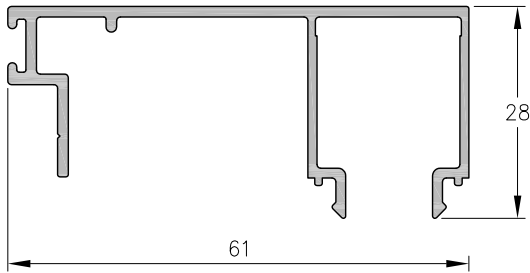

1110067 - Cierre marco F/M  
Peso: 0,55 Kg/m  
Largo Std.: 6030 mm

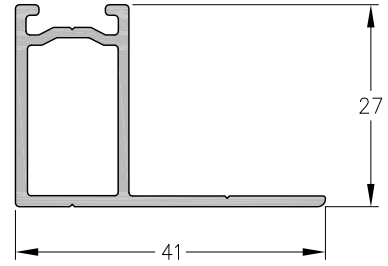

1110069 - Guía fija móvil  
Peso: 0,42 Kg/m  
Largo Std.: 6150 mm

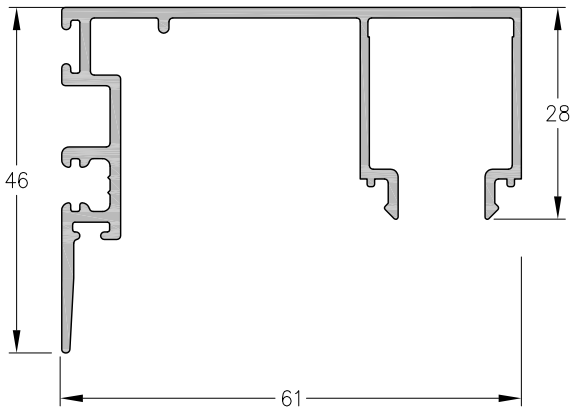

1110068 - Cierre parante F/M  
Peso: 0,71 Kg/m  
Largo Std.: 6030 mm

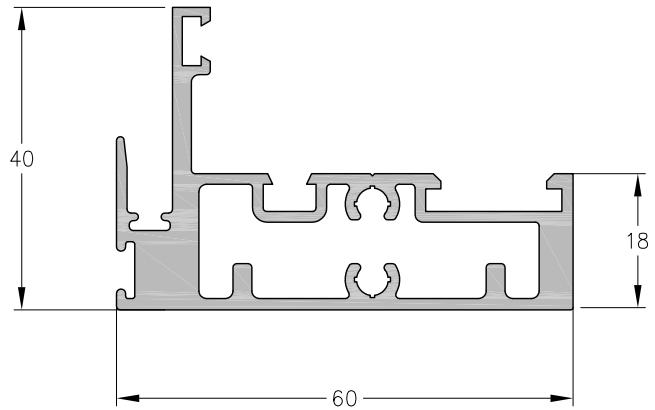

1110065 - parante F/M 40 mm  
Peso: 1,30 Kg/m  
Largo Std.: 6030 mm

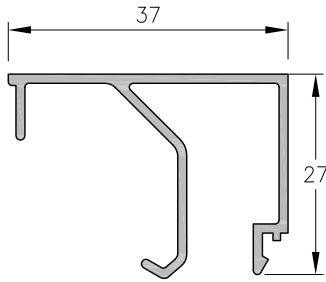

4045 - Contravidrio  
Recto 37 mm.  
Peso: 0.351 Kg/m.  
Largo Std.: 6.200 mm.

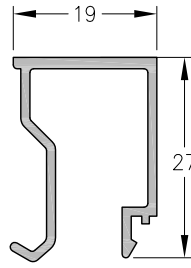

4046 - Contravidrio  
Recto P/DVH.  
Peso: 0.273 Kg/m.  
Largo Std.: 6.200 mm.

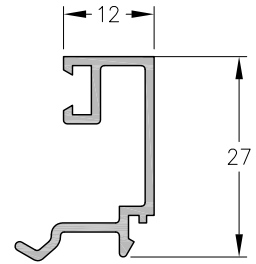

4049 - Contravidrio  
Recto L.E..  
Peso: 0.232 Kg/m.  
Largo Std.: 6.200 mm.

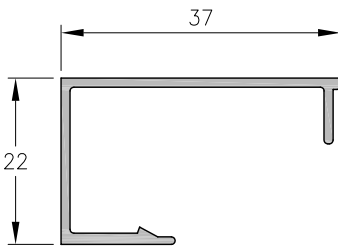

1110051 - Contravidrio  
recto 37 mm para clip  
Largo Std.: 6030 mm  
peso: 0,27 Kg/m

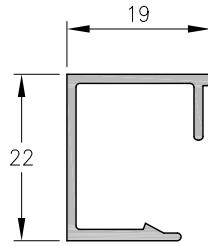

1110052 - Contravidrio  
recto 19 mm para clip  
Largo Std.: 6030 mm  
peso: 0,21 Kg/m

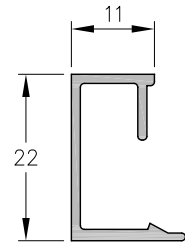

1110053 - Contravidrio recto  
11 mm para clip  
Largo Std.: 6030 mm  
peso: 0,19 Kg/m

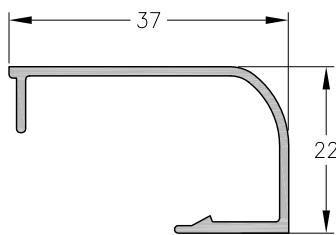

4047 - Contravidrio  
Curvo 37 mm.  
Peso: 0.254 Kg/m.  
Largo Std.: 6.200 mm.

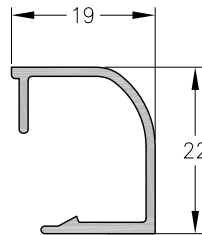

4048 - Contravidrio  
Curvo P/DVH.  
Peso: 0.196 Kg/m.  
Largo Std.: 6.200 mm.

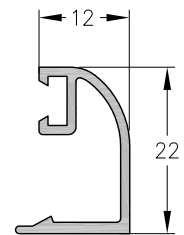

4050 - Contravidrio  
Curvo L.E..  
Peso: 0.191 Kg/m.  
Largo Std.: 6.200 mm.

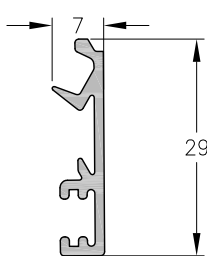

1020649 - Contramarco  
Peso: 0,19 Kg/m  
Largo Std.: 6150 mm

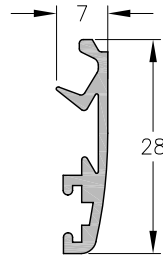

1020657 - Contramarco  
Peso: 0,19 Kg/m  
Largo Std.: 6150 mm

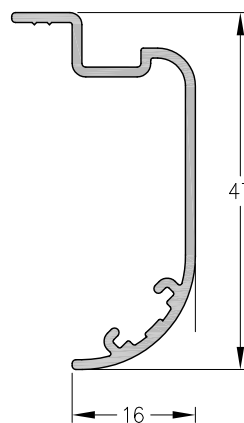

1020641 - Contramarco  
Peso: 0,32 Kg/m  
Largo Std.: 6150 mm

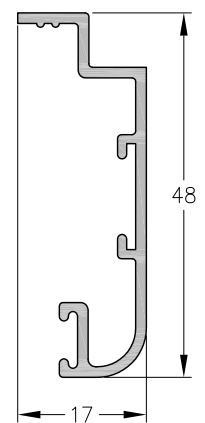

3083 - Contramarco  
Peso: 0,35 Kg/m  
Largo Std.: 6150 mm

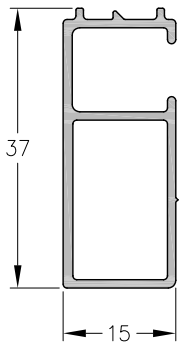

1020718 - Premarco 36 mm  
Largo Std.: 6150 mm  
peso: 0,33 Kg/m

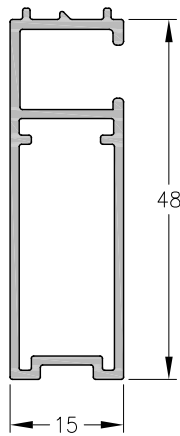

1060647 - Premarco de 48 mm.  
Peso: 0,46 Kg/m.  
Largo Std.: 6.150 mm.

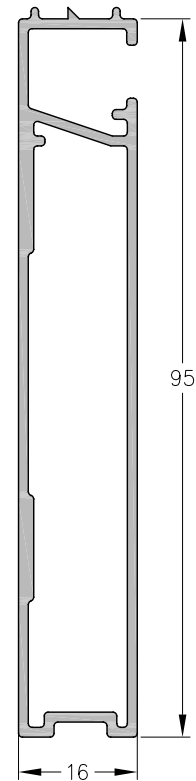

1060875 - Premarco  
largo std.: 6150 mm  
peso: 0,88 Kg/m

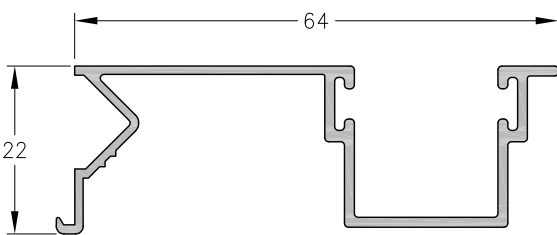

1020722 - Guía Común  
Peso: 0,49 Kg/m  
Largo Std.: 6150 mm

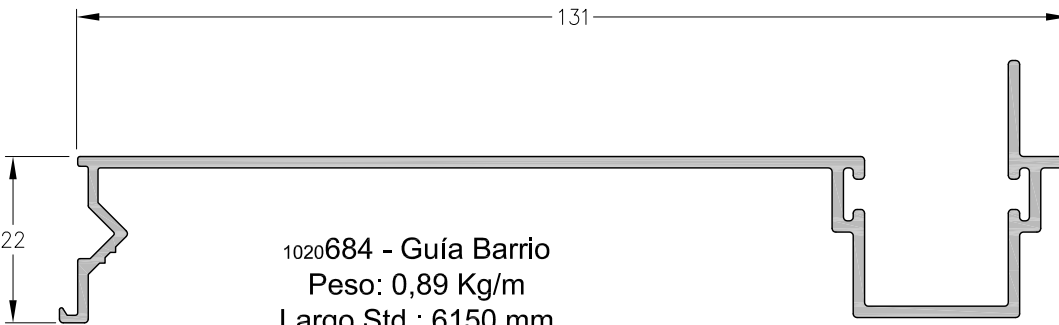

1020684 - Guía Barrio  
Peso: 0,89 Kg/m  
Largo Std.: 6150 mm

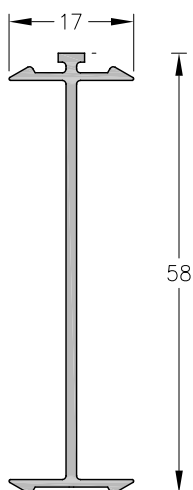

**1110204 - Perfil de acople**  
Peso: 0,31 Kg/m  
Largo Std.: 6150 mm

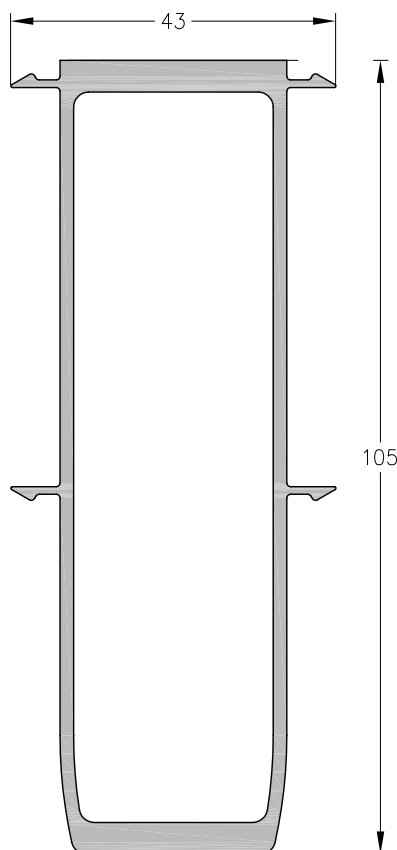

**1110299 - Perfil de acople reforzado**  
Peso: 1,67 Kg/m  
Largo Std.: 6150 mm

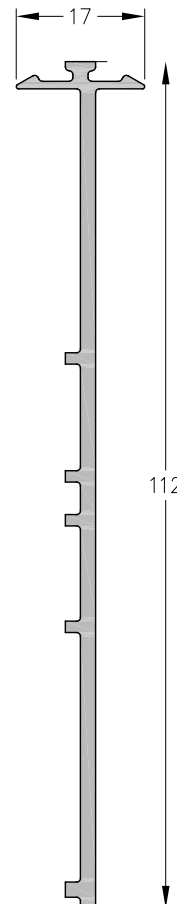

**1110447 - Acople 180°**  
Peso: 0,70 Kg/m  
Largo Std.: 6150 mm

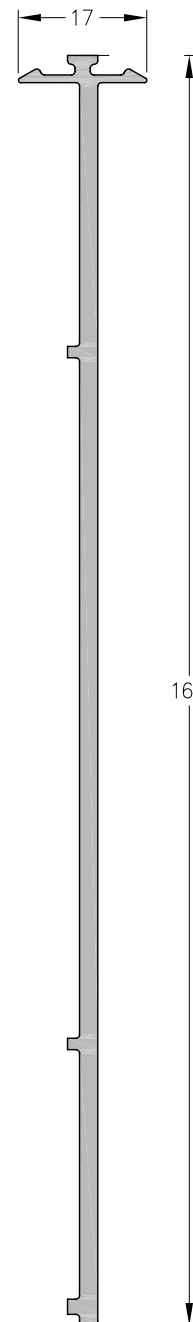

**1110701 - Acople 3 guías**  
Peso: 1,16 Kg/m  
Largo Std.: 6150 mm

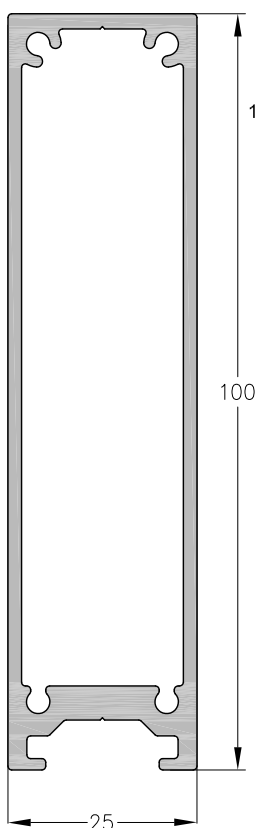

**1110999 - Refuerzo inercial 100 mm**  
Peso: 1,45 Kg/m  
Largo Std.: 6150 mm

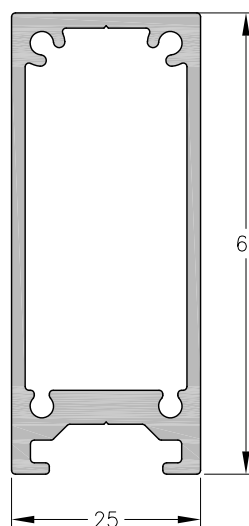

**1110998 - Refuerzo inercial 61 mm**  
Peso: 1,08 Kg/m  
Largo Std.: 6150 mm

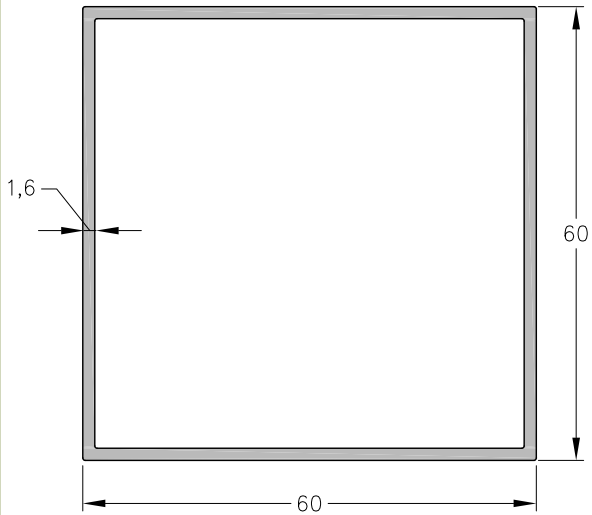

1090459 - Tubo 60 x 60 mm  
Peso: 1,01 Kg/m  
Largo Std.: 6030 mm

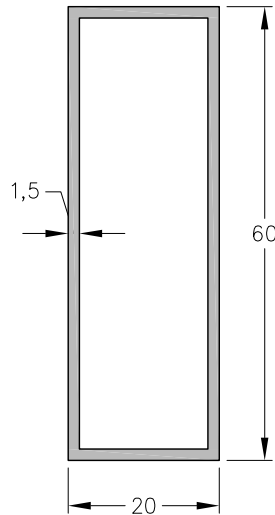

1090812 - Tubo 60 x 20 mm  
Peso: 0,63 Kg/m  
Largo Std.: 6030 mm

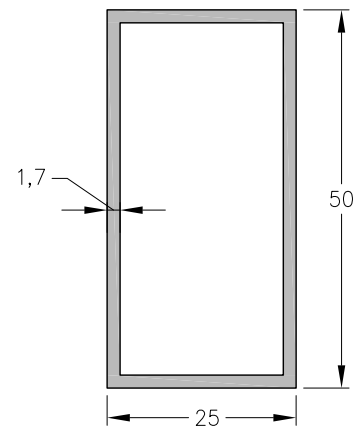

1090809 - Tubo  
50 x 25 mm.  
Peso: 0,55 Kg/m.  
Largo Std.: 6.030 mm.

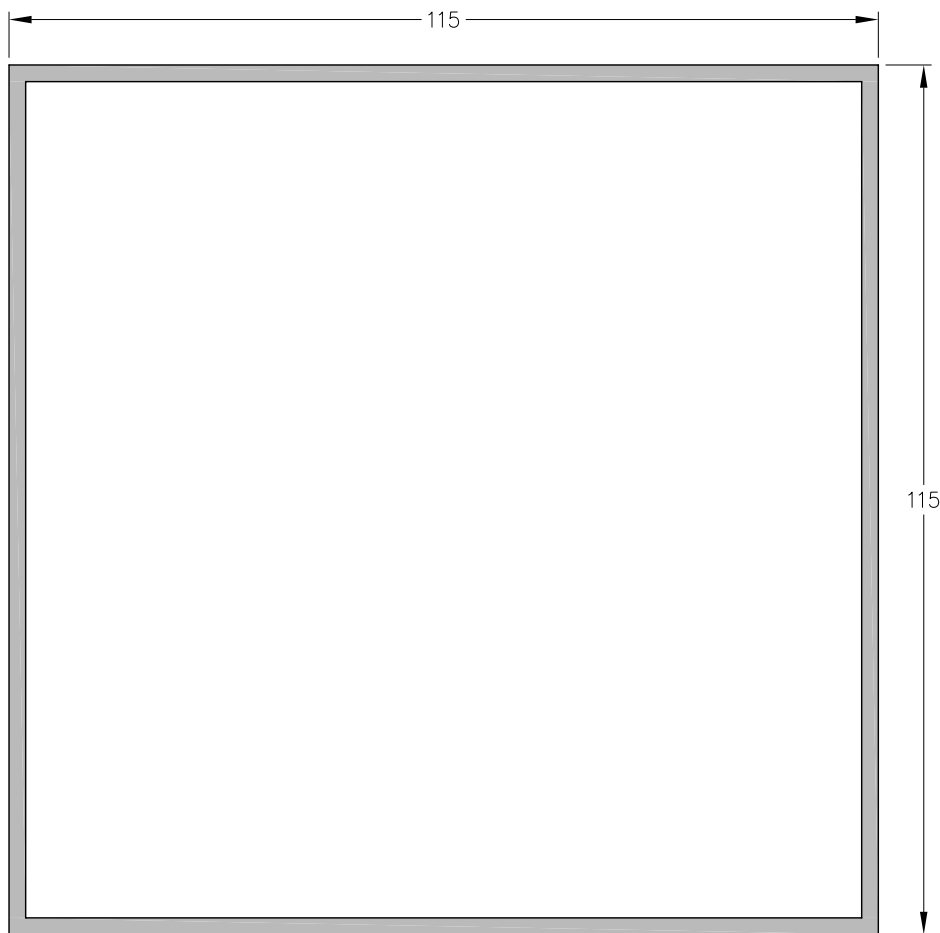

1090700 - Tubo 115 x 115 mm e: 2,2  
Peso: 2,68 Kg/m  
Largo Std.: 6150 mm